

EZ Fold® TF-20S-B

Basketball Backstop—Ceiling-Suspended, Forward-Folding, Front-Braced

by **DRAPER**

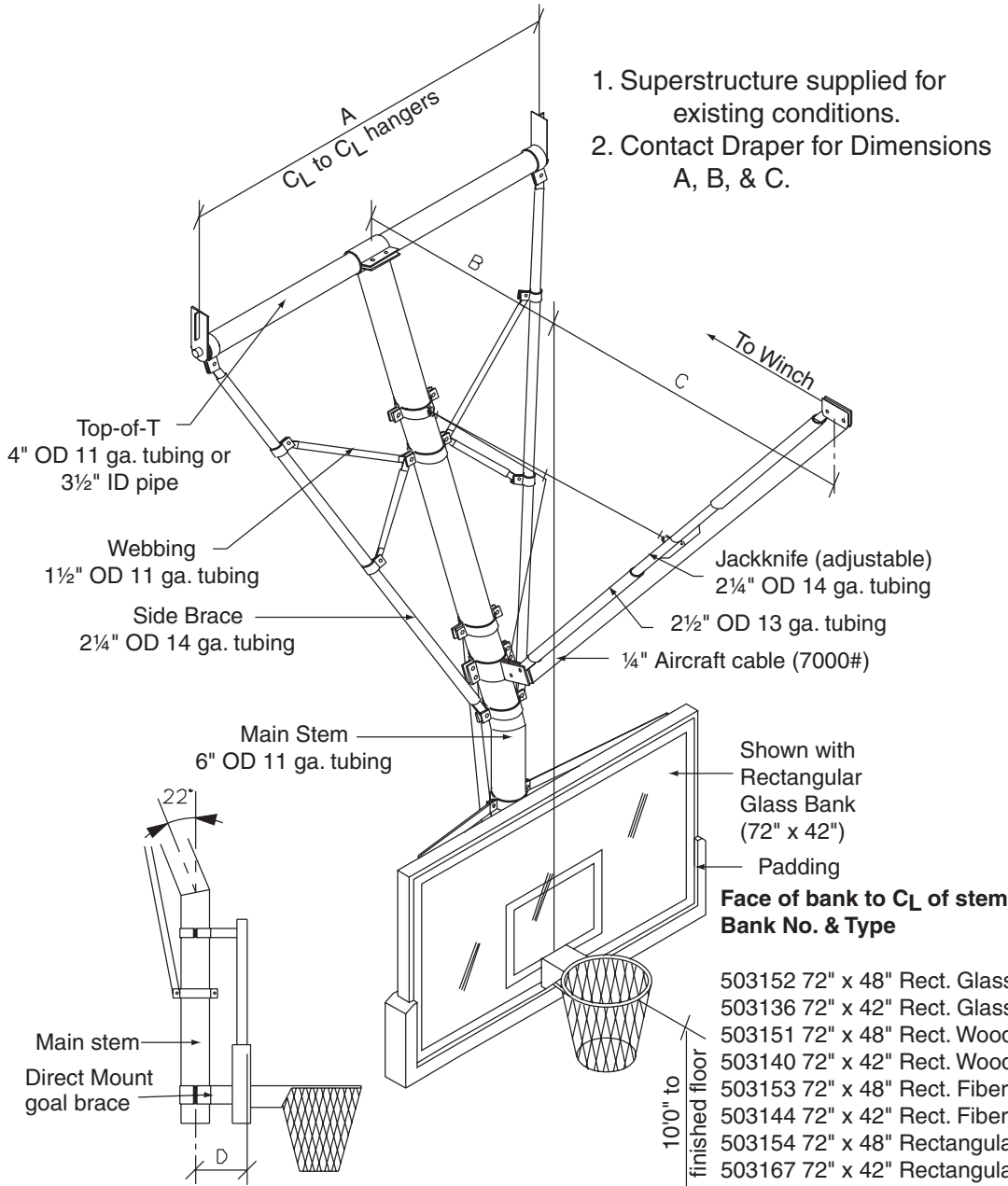

Side View/Goal Brace Detail
 "Goal Brace" feature attaches directly behind goal mounting plate and directly to main stem of backstop, which eliminates strain on backboards.

Draper offers a 25-year limited warranty on the EZ Fold basketball backstop structure. No other basketball backstop manufacturer offers you this protection. For a copy of the EZ Fold backstop warranty in its entirety, contact Draper, Inc.

DRAPER®

411 S. Pearl St., Spiceland, IN 47385 USA ■ 765-987-7999
 www.draperinc.com ■ fax 765-987-7142
 Copyright © 2010 Draper Inc. Form EZ-TF-20S-B_Sub10 Printed in U.S.A.

PROJECT: _____

 ARCHITECT: _____
 CONTRACTOR: _____
 SUPPLIER: _____
 DATE: _____ REVISED: _____

EZ Fold® TF-20S-B

**Basketball Backstop—Ceiling-Suspended,
Forward-Folding, Front-Braced**

Specifications—EZ Fold TF-20S-B

Ceiling-Suspended, Forward-Folding Backstop (Over 27'7")

Product Description

Basketball backstop shall be the EZ FOLD TF-20S-B, ceiling-suspended, forward-folding by Draper, Inc. of Spiceland, IN.

Backstops shall be a bolt-together main frame constructed from steel mechanical tubing to form a rigid tetrahedral "T" design of back-to-back right triangles. The main stem (center strut) shall be 6" OD 11-gauge steel tubing, the top of the "T" shall be 4" OD 11-gauge steel tubing or 3½" I.D. pipe (above 31'-2"), and the side braces shall be 2¼" OD 14-gauge steel tubing. Side braces shall join stem no higher than 4'-6" above goal. Main frame shall include 4, 1½" OD 11-gauge steel tubing members (webbing) x bracing side braces to main stem.

The folding front brace shall be jackknife type, fully adjustable, self-locking in the down position and constructed of 2½" OD 13-gauge (outer) steel tubing and 2¼" OD 14-gauge (inner) steel tubing.

The main backstop frame shall be suspended diagonally from the superstructure with a 22-degree angle with a vertical member of length sufficient to allow plus or minus 6" height adjustment of either fan or rectangular banks. The backstop shall be supported from 4" OD 11-gauge steel mechanical tubing (as shown on plans) anchored to roof structure by means of heavy steel support hangers. Superstructure tubes shall be reinforced with bridging and/or bracing when truss centers exceed 8'-0".

Pivot or hinge joint (pin height) for folding shall not exceed 15" from roof structure except when required by architect for coordination with other trades. The main backstop frame shall pivot on 1¼" minimum solid steel shaft secured in a milled bearing hole in ½" minimum steel plate hangers to insure accurate positioning of bank.

The bank shall be attached to the 6" OD main stem by heavy-duty bank hangers. Hangers shall be constructed of 2¼" OD 14-gauge steel tubing and ¼" x 2" flat steel plate with slotted holes for lateral adjustment. All glass banks shall have one upper bank hanger and include a goal brace which attaches directly to the goal mounting plate and directly to the 6" main stem of the backstop to eliminate any strain on the bank and help prevent glass breakage. This direct mount feature shall conform to NCAA recommendation No. 5-F (dated Mar. 82) which states that the design of the unit shall transfer the load on the goal directly to the backboard support so as to minimize stress to the glass backboard.

Backstop is raised or lowered by a ¼" (6.35 mm) aircraft cable, certified minimum break strength of 7,000 pounds (3178 kg), operating over aluminum alloy sheaves with bronze oilite bearings that do not require lubrication.

Backstop shall have a black or white powder coat finish. Other colors optionally available: contact Draper for details.

Operation: Backstop shall be operated by 503085 motorized winch. For complete specifications, see separate sheets.

Options

Backstop can be provided with any of several different styles of backboards, goals and padding. Specify types desired. See separate sheets.

Accessories

Smart Gym Control System. For group control of Basketball Backstops with Electric Winches, Electric Divider Curtains, Electric Height Adjusters and other Auxiliary Devices. For complete specifications, see separate sheet.

503060 EZ Power Wireless Remote Control. For remote control operation of electric winch. For complete specifications, see separate sheet.

503029—Safety belt to automatically lock basketball backstop in position due to a sudden surge of speed created by a possible malfunction of the hoisting apparatus. For complete specifications, see separate sheet.

Height Adjusters (see separate sheets):

503093— For motorized 8'-10' Height Adjustment of rectangular bank.

503097— For motorized 8'-10' Height Adjustment of fan bank.

503095— For motorized 8'-10' Height Adjustment of rectangular bank with wireless remote control.

503098— For motorized 8'-10' Height Adjustment of fan bank with wireless remote control.

503096— For motorized 8'-10' Height Adjustment of rectangular bank with EZ Stick Power Wand.

503099— For motorized 8'-10' Height Adjustment of fan bank with EZ Stick Power Wand.

503092— For manual 8'-10' height adjustment of rectangular backboards.

503094— For manual 8'-10' height adjustment of fan backboards.

503003—Portable Height Adjuster Operator—Speed controlled battery powered operator for manual height adjusters. For complete specifications, see separate sheet.

LEED® Submittal Information

Credit	Measure	
	MRc4 – Recycled Content	Post Consumer Average 51.21%
MRc5 – Regional Materials	Raw materials are commodity items from multiple sources so extraction point cannot be determined. Final Manufacturing/Assembly in Spiceland, IN 47385.	

**Downloadable 3-part specifications
are available at www.draperinc.com.**