

502021 Double Mat Lifter

Mat Lifter for Two Wrestling Mats

by DRAPER

Specifications—Double Mat Lifter

_____ mat lifters shall be model #502021 by Draper, Inc., Spiceland, Indiana.

Mat lifter construction shall consist of a welded steel frame, with all drive and lifting mechanism enclosed in a sheet metal housing. Unit shall be a two cable system to assure balanced operation. Cables shall be attached to the welded frame and pass through sheave blocks attached to the load bar, which shall be connected to fabric slings. Standard lifter, load bar, and slings shall be capable of supporting two standard 42' x 42' wrestling mats (weighing approximately 1 lb./sq. ft.) with 5 to 1 safety ratio. Mats may be one-piece or in sections placed end to end.

Each unit shall consist of a 210:1 ratio double reduction worm-worm attached to an instantly reversing 2 HP motor, operating with 208/230/460 volts in 3-phase, including a 6 ft.-lb. electric safety brake. Lifting and lowering speed shall be approximately 5 feet per minute.

Lifting drums shall be machine synchronized for cable wrap and driven by a 210:1 ratio gear box. Drum shaft shall be 1 7/16" diameter cold-finished steel. Two steel lift cables shall be 9/16" 6-strand, 37 wires per strand, fiber core. Cables shall be rated at 1704 lbs. each at a 5-to-1 safety factor.

Load bar shall be connected to two 40 lb. per square foot vinyl fabric slings with heavy duty straps and fasteners. Standard sling color is black; other colors are available by special request. Fabric sling incorporates continuous straps that wrap completely around mat to prevent mat from falling should fabric sling become torn. For safety purposes, sling capacity shall govern the lift capacity of the system.

Motors, drive assembly, and all control mechanisms shall be encased in a fireproof safety cover.

Movement control shall be by surface mounted control enclosure with limit switches.

Wiring and conduit from hoist to key switch and electrical hook-up of unit by others.

Approximate unit weight shall be 1,900 lb. (not including mat).

Structural support members and wall connections by others to meet building and unit requirements.

For traveling mat lifter, add the following paragraph:

Mat lifter travel kit shall be driven by a .50 HP motor operating with 208/230/460 volts in 3 phase attached to a 60:1 ratio gear box with non-pneumatic wheel (s).

End first travel kit for mat lifter shall have two 1-ton machined trolleys with festooning power cables. Sideways travel models shall have four half-ton machined trolleys with festooning power cables. Motors, drive assembly, and all control mechanisms shall be encased in a fireproof safety cover.

Wall Mounting Option:

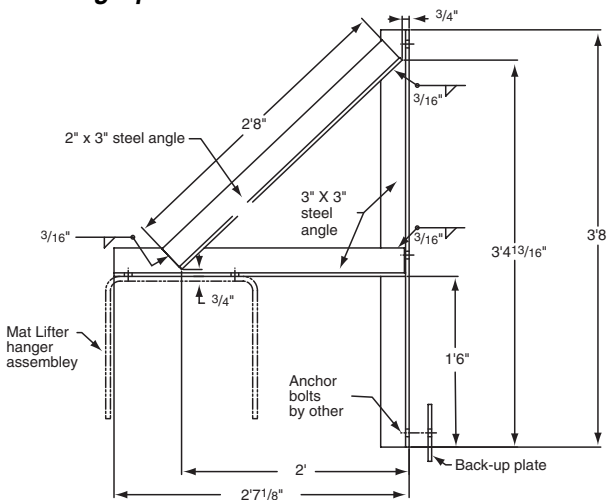

Select Hoist Options:

- Stationary
- Traveling
 - End First Travel Kit*
 - Sideways Travel Kit*

*For Travel Kits, please provide the following information:

Runway Beam (by others)

Length: _____ Elevation: _____

Type: S W Other

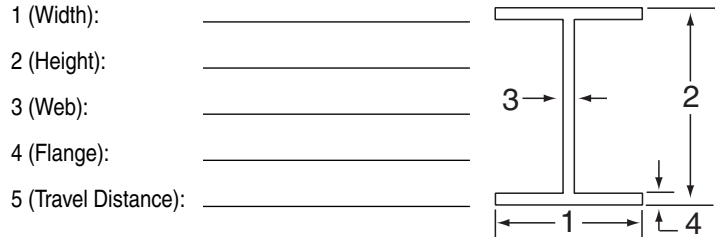

Select Motor Options:

- 208v AC—3-Phase
- 230v AC—3-Phase
- 460v AC—3-Phase

Mounting Options:

- Beam Mount
 - Perpendicular to structural support beams (standard)
 - Parallel to structural support beams (requires optional 502024 Beam Clamp Kit)
- Wall Mount (requires optional 502023 Wall Bracket Kit)

Suspended Mounting Options:

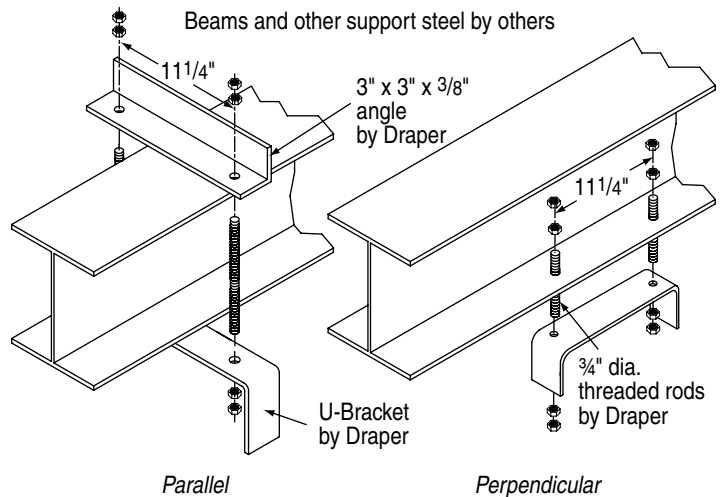

DRAPER

411 S. Pearl St., Spiceland, IN 47385 USA ■ 765-987-7999
www.draperinc.com ■ fax 765-987-7142

Copyright © 2007 Draper Inc. Form 502021-MatLifter_Sub07 Printed in U.S.A.

PROJECT: _____

ARCHITECT: _____

CONTRACTOR: _____

SUPPLIER: _____

DATE: _____ REVISED: _____

502021 Double Mat Lifter—Stationary

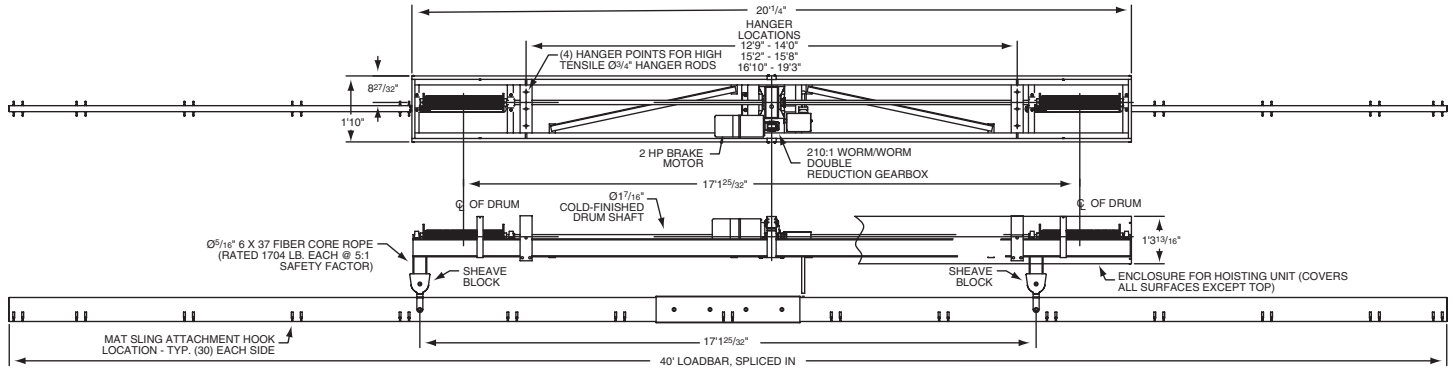

Sideways Traveling Kit

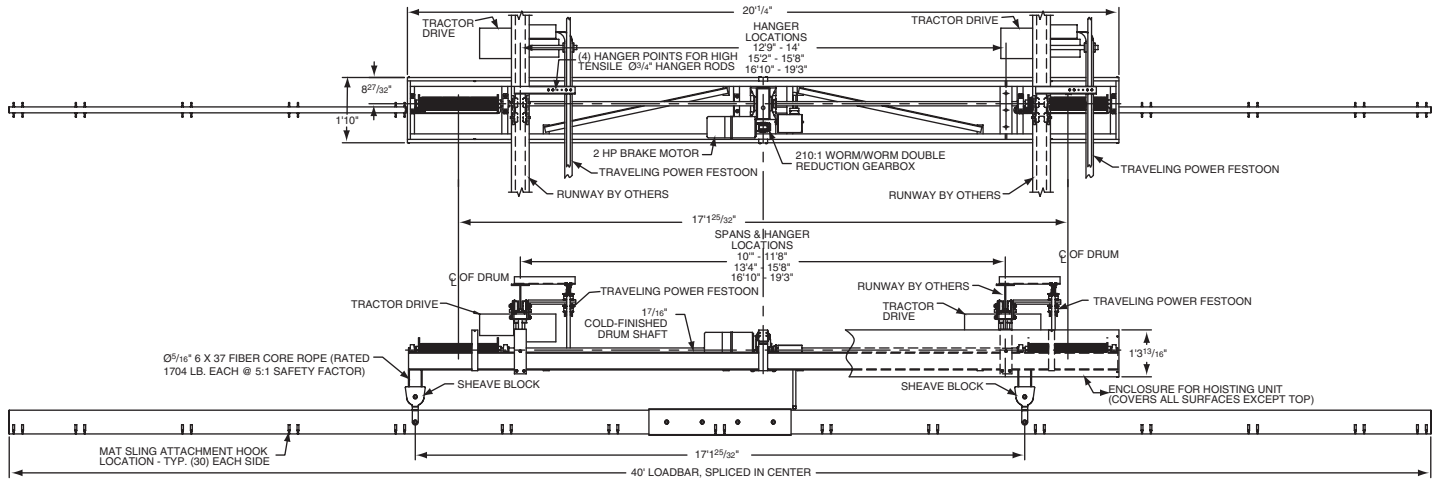

End First Traveling Kit

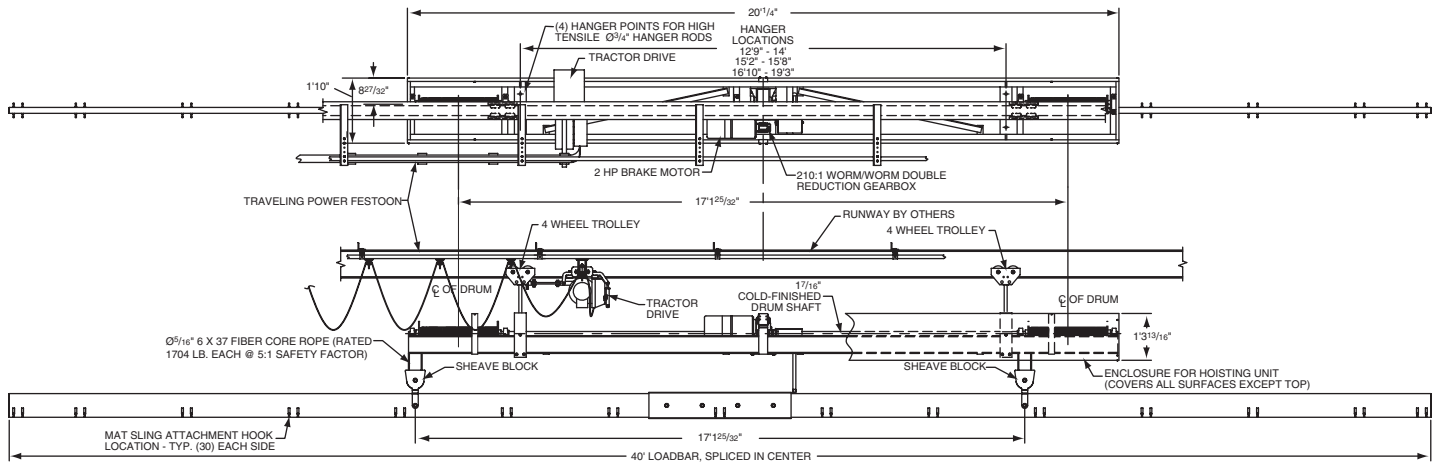

502021—End Views

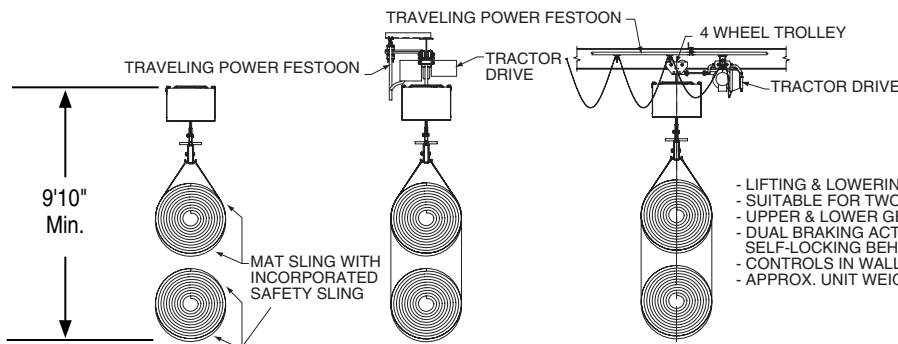

- LIFTING & LOWERING SPEED APPROX. 5 FPM
- SUITABLE FOR TWO 42' X 42' MAT, 1.0 LB/FT
- UPPER & LOWER GEARED TRAVEL LIMIT SWITCHES
- DUAL BRAKING ACTION - MOTOR BRAKE PLUS SELF-LOCKING BEHAVIOR OF WORM GEARS
- CONTROLS IN WALL-MOUNT ENCLOSURE SHIPPED LOOSE
- APPROX. UNIT WEIGHT - 2000 LB.

NOTE: MAT SLINGS ARE DESIGNED FOR 2" DIA. MAT MAXIMUM

Stationary

End First Travel

Sideways Travel

Wiring Diagram—Stationary (230/460-3-60)*

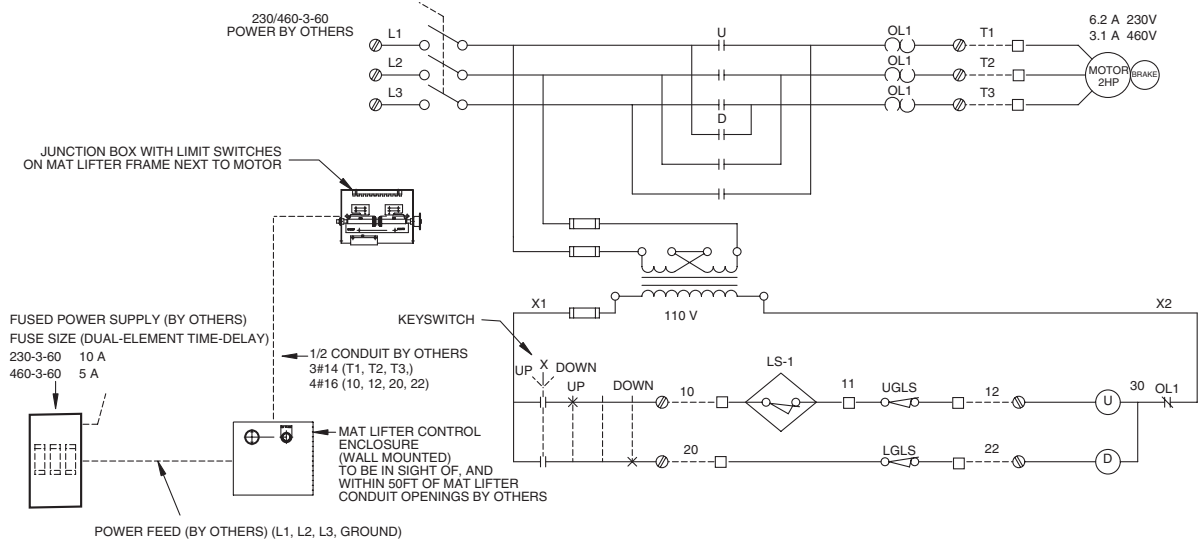

Wiring Diagram—Stationary (208Y/120-3-60)*

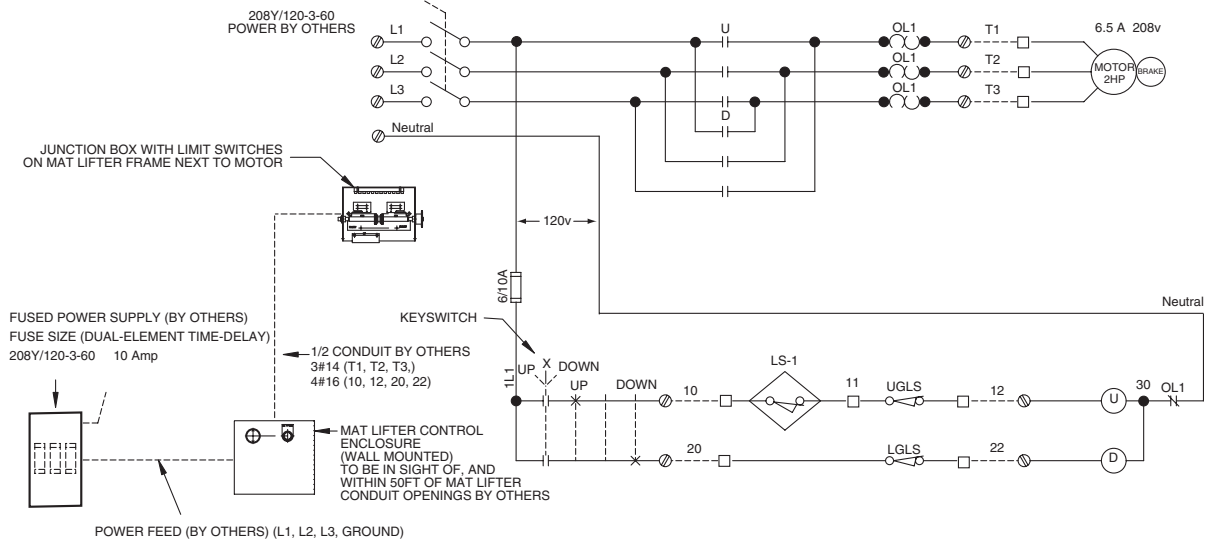

Wiring Diagram—Traveling (230/460-3-60)*

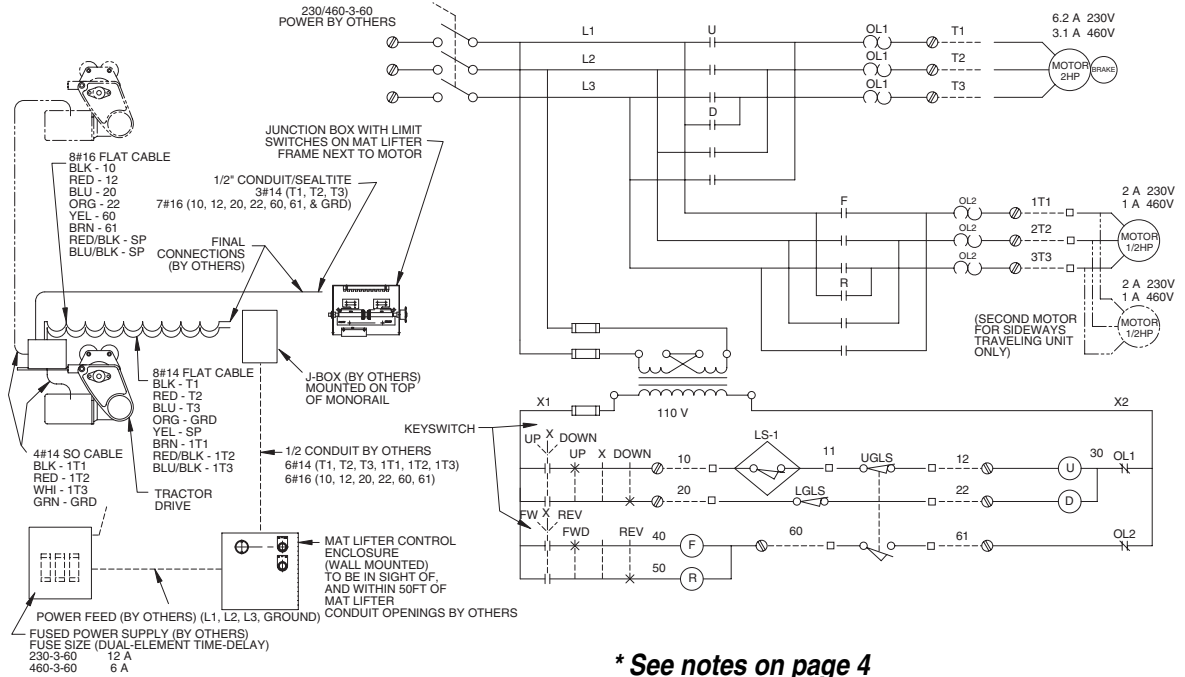

* See notes on page 4

Wiring Diagram—Traveling (208Y-120-3-60)*

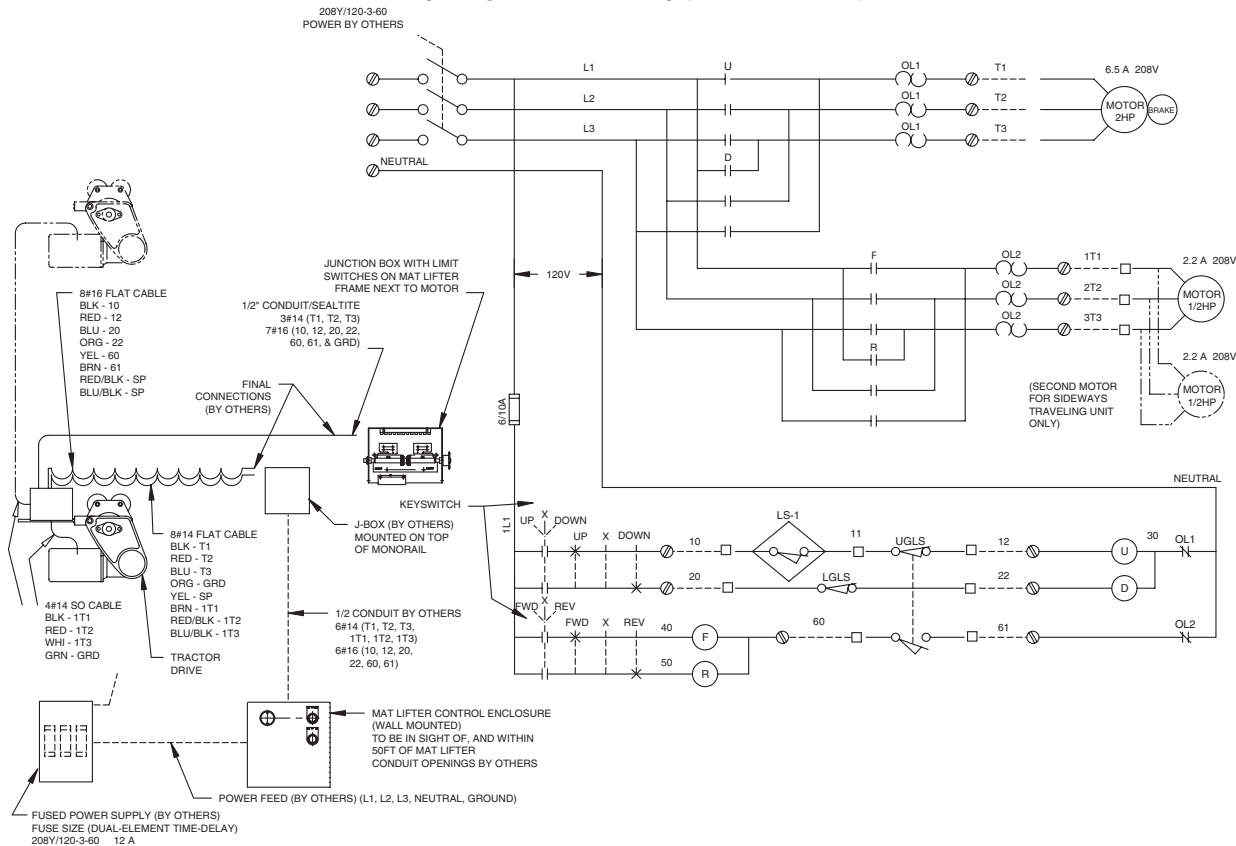

*Wiring Notes

Danger:
Before installing, removing, inspecting, or performing any maintenance on this unit, the main switch shall be de-energized. Lock and tag the main switch in the de-energized position in accordance with ANSI Z244.1.
This unit shall be installed and wired in accordance with ANSI/NFPA 70, National Electrical Code, and all applicable Federal, State, and Local Codes. Failure to read and comply with this and other warnings may result in serious bodily injury or death and/or property damage.

- LS-1 UPPER CONTACT PROXIMITY SWITCH 1 (EMERGENCY OVERTRAVEL)(TRIPPED IF LOADBAR IS TOO HIGH)
- UGLS UPPER GEARED LIMIT SWITCH (TRIPPED WHEN LOADBAR IS AT DESIRED UP POSITION)
- LGLS LOWER GEARED LIMIT SWITCH (TRIPPED WHEN LOADBAR IS AT DESIRED LOWER POSITION)
- FIELD WIRING PROVIDED BY OTHERS
- ⊗ TERMINALS IN CONTROLS MOUNTED TO WALL
- TERMINALS IN MAT LIFTER UNIT

Control Box

